

Angular Momentum System of Particles Concept Questions

Question 1: Angular Momentum

A non-symmetric body rotates with an angular speed ω about the z axis.

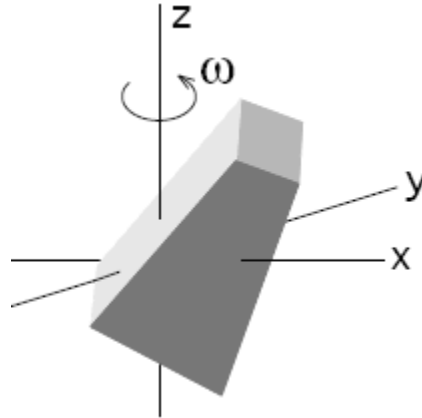

Relative to the origin

1. \vec{L}_0 is constant.
2. $|\vec{L}_0|$ is constant but $\vec{L}_0/|\vec{L}_0|$ is not.
3. $\vec{L}_0/|\vec{L}_0|$ is constant but $|\vec{L}_0|$ is not.
4. \vec{L}_0 has no z-component. .

Answer 2. For this non-symmetric rigid body, the angular momentum about the origin has time varying components in the x-y plane, $\vec{L}_0 = L_z \hat{k} + L_r \hat{r}(t)$, (where $\hat{r}(t)$ is a radial unit vector pointing outward from the origin) The magnitude of $|\vec{L}_0|$ is constant because both L_z and L_r are constant. The direction of $\hat{r}(t)$ in the x-y plane depends on the instantaneous orientation of the body and so the direction of $\vec{L}_0/|\vec{L}_0|$ is changing.

Question 2: A rigid body with rotational symmetry rotates with an angular speed ω about its symmetry axis (z axis).

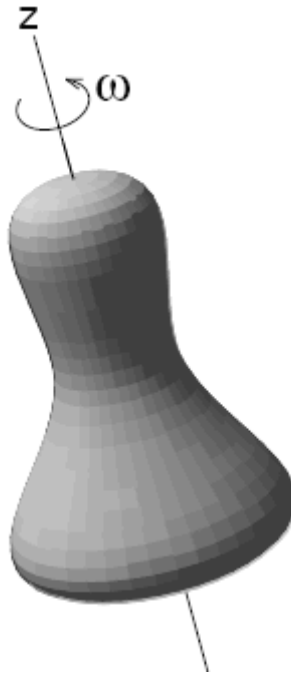

Relative to the origin

1. \vec{L}_0 is constant.
2. \vec{L}_0 is constant but $\vec{L}_0 / |\vec{L}_0|$ is not.
3. $\vec{L}_0 / |\vec{L}_0|$ is constant but \vec{L}_0 is not.
4. \vec{L}_0 has no z-component. .

Answer 1. For a symmetric body, all the non-z components of the angular momentum about any point along the z-axis cancel in pairs leaving only a constant non-zero z-component of the angular momentum so \vec{L}_0 is constant.

Question 3 Twirling Person A woman, holding dumbbells in her arms, spins on a rotating stool (assume that the stool has no frictional torque acting along the axis of rotation). When she pulls the dumbbells inward, her moment of inertia about the vertical axis passing through her center of mass changes and she spins faster. The z-component of the angular momentum about that axis is

1. the same.
2. larger.
3. smaller.
4. not enough information is given to decide.

Answer 1. Call the rotation axis the z-axis. Because we assumed that there are no external torques in the z-direction acting on the woman then the z-component of her angular momentum about the axis of rotation is constant. (Note if we approximate the figure skater as a symmetric body about the z-axis than there are no non-z-components of the angular momentum about a point lying along the rotation axis.)

Question 4 Figure Skater A figure skater stands on one spot on the ice (assumed frictionless) and spins around with her arms extended. When she pulls in her arms, she reduces her rotational moment of inertia and her angular speed increases. Assume that the z-component of her angular momentum is constant. Compared to her initial rotational kinetic energy, her rotational kinetic energy after she has pulled in her arms must be

1. the same.
2. larger.
3. smaller.
4. Not enough information is given to decide.

Answer 2. Call the rotation axis the z-axis. When she pulls her arms in there are no external torques in the z-direction so her z-component of her angular momentum about the axis of rotation is constant. The magnitude of her angular momentum about the rotation axis passing through the center of the stool is $L = I\omega$. Her kinetic energy is

$$K = \frac{1}{2}I\omega^2 = \frac{1}{2}I\frac{L^2}{I^2} = \frac{L^2}{2I}.$$

Since L is constant and her moment of inertia decreases when she pulls her arms, her kinetic energy must increase. (Note if we approximate the figure skater as a symmetric body about the z-axis than there are no non-z-components of the angular momentum about a point lying along the rotation axis.)

Question 5 A tetherball of mass m is attached to a post of radius R by a string. Initially it is a distance r_0 from the center of the post and it is moving tangentially with a speed v_0 . The string passes through a hole in the center of the post at the top. The string is gradually shortened by drawing it through the hole. Ignore gravity. Until the ball hits the post,

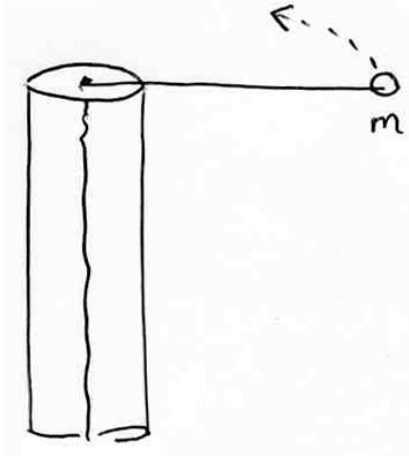

1. The energy and angular momentum about the center of the post are constant.
2. The energy of the ball is constant but the angular momentum about the center of the post changes.
3. Both the energy and the angular momentum about the center of the post, change.
4. The energy of the ball changes but the angular momentum about the center of the post is constant.

Answer: 4. The tension force points radially in; so torque about central point is zero: angular momentum about central point is constant.

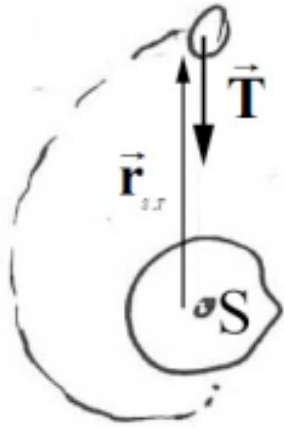

$$\vec{\tau}_S = \vec{r}_{S,T} \times \vec{T} = \vec{0}$$

$$\vec{L}_{S,f}^{system} = \vec{L}_{S,0}^{system}$$

For all radial forces, (example gravitation), the angular momentum about the central point is a constant of the motion. A small displacement of the ball has a radially component inward so the work done by tension is not zero.,

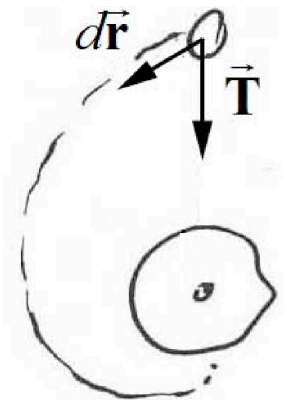

$$dW^{ext} = \vec{T} \cdot d\vec{r} \neq 0.$$

Hence the mechanical energy is not constant.

Question 6: A tetherball of mass m is attached to a post of radius R by a string. Initially it is a distance r_0 from the center of the post and it is moving tangentially with a speed v_0 . The string wraps around the outside of the post. Ignore gravity. Until the ball hits the post,

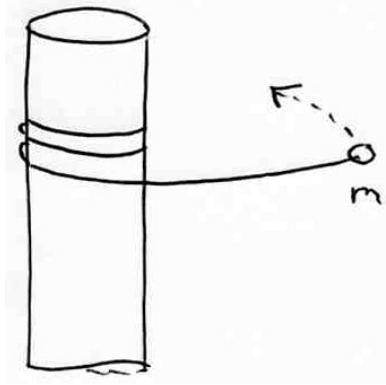

1. The energy and angular momentum about the center of the post are constant.
2. The energy of the ball is constant but the angular momentum about the center of the post changes.
3. Both the energy of the ball and the angular momentum about the center of the post, change.
4. The energy of the ball changes but the angular momentum about the center of the post is constant.

Answer 2. The tension force points towards contact point; so torque about central point is not zero: angular momentum about central point is not constant.

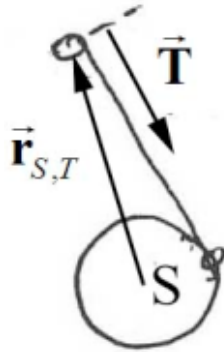

$$\vec{\tau}_S = \vec{r}_{S,T} \times \vec{T} \neq \vec{0}$$

$$\vec{L}_{S,f}^{system} \neq \vec{L}_{S,0}^{system}$$

Small displacement is always perpendicular to string since at each instant in time ball undergoes instantaneous circular motion about string contact point with pole.

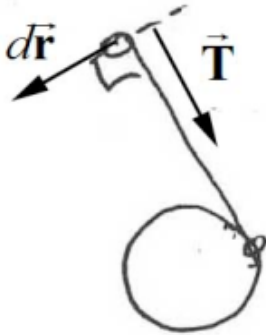

$$dW^{ext} = \vec{T} \cdot d\vec{r} = \vec{0}$$

Therefore the tension force is perpendicular to the displacement. Hence mechanical energy is constant.

MIT OpenCourseWare
<http://ocw.mit.edu>

8.01SC Physics I: Classical Mechanics

For information about citing these materials or our Terms of Use, visit: <http://ocw.mit.edu/terms>.