

2.003 Engineering Dynamics

Problem Set 6 with concept question answers

Problem 1: A slender uniform rod of mass m_2 is attached to a cart of mass m_1 at a frictionless pivot located at point „A“. The cart is connected to a fixed wall by a spring and a damper. The

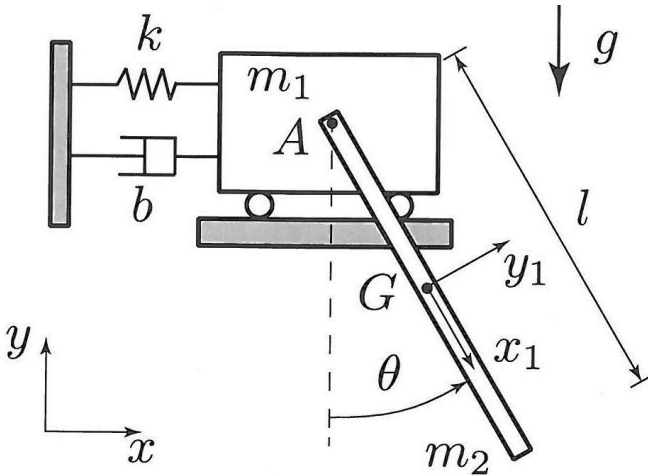

Figure 1. Cart with a slender rod

cart rolls without friction in the horizontal direction. The position of the cart in the inertial frame O_{xyz} is given by $x\hat{i}$.

a). Assuming that the motion of the cart and slender rod is the result of initial conditions only, find expressions for T and V , the kinetic and potential energy of the system in terms of x , \dot{x} , θ , and $\dot{\theta}$.

Concept question: The kinetic energy of the rod may be expressed by the

equation $T_{rod} = \frac{1}{2} I_{zz/A} \dot{\theta}^2$: a). True, b).

False. Answer: False—the rod also has velocity terms involving \dot{x} , the velocity of the cart.

Problem 2:

Two identical masses are attached to the end of massless rigid arms as shown in the figure. The vertical portion of the rod is held in place by bearings that prevent vertical motion, but allow the shaft to rotate without friction. A torsion spring with spring constant K_t resists rotation of the vertical shaft. The shaft rotates with a time varying angular velocity Ω with respect to the O_{xyz} inertial frame. The arms are of length L . The frame $A_{x_1y_1z_1}$ rotates with the arms and attached masses. Note that the angle ϕ is fixed.

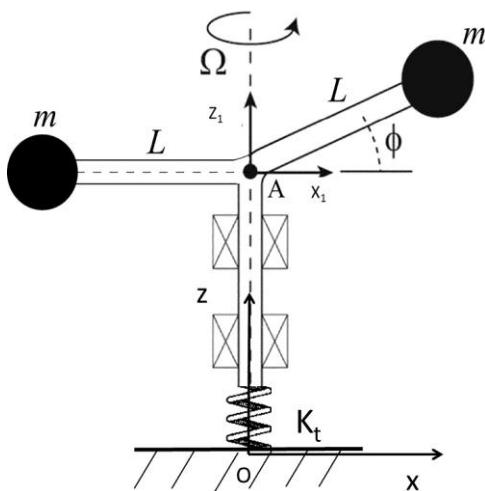

The shaft rotates with a time varying angular velocity Ω with respect to the O_{xyz} inertial frame. The arms are of length L . The frame $A_{x_1y_1z_1}$ rotates with the arms and attached masses. Note that the angle ϕ is fixed.

a) Find T and V , the kinetic and potential energy for this system.

Concept question: Is it possible to find the equation of motion of this system by requiring that:

$\frac{d}{dt}[T+V]=0$. a). Yes, b). No. Answer: Yes, this is a useful approach for single dof problems with no non-conservative forces.

Problem 3: A particle of mass m slides down a frictionless surface. It then collides with and sticks to a uniform vertical rod of mass M and length L . Following the collision, the rod pivots about the point O . Point G is the mass center of the rod.

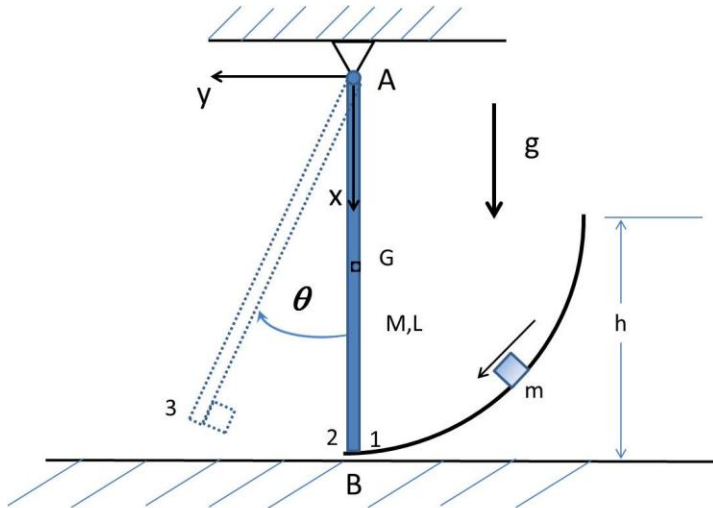

a). Find the kinetic energy, T , and the potential energy, V , of the system after the collision as a function of θ and $\dot{\theta}$.

Concept question: Angular momentum with respect to point A and $(T+V)$ are both constant after the collision. A). True, B)False. Answer: False, $T+V=$ constant, but angular momentum is not.

Problem 4:

A pendulum consists of a rectangular plate (of thickness t) made of a material of density ρ , with two identical circular holes (of radius R). The pivot is at A .

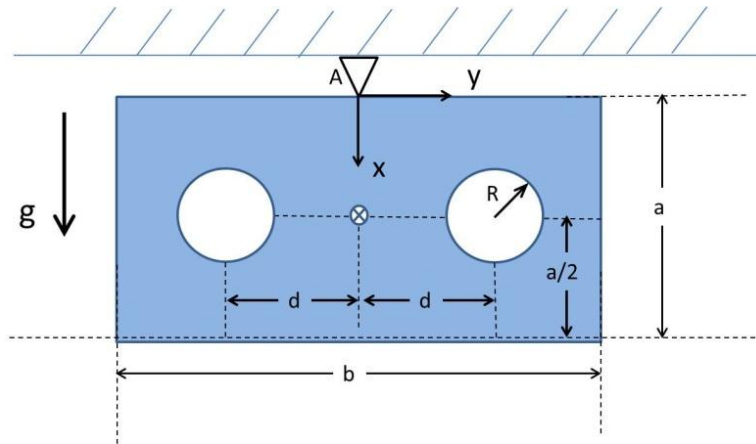

a). Find expressions for T and V , the kinetic and potential energies of the system in terms of the angle of rotation about point A .
 b). This is a planar motion problem. How many degrees of freedom does this body have. What are the constraints on this rigid body.

Concept question: According to a strict definition of „translation“: “All points on a rigid body must travel in parallel paths”, does this rigid body exhibit rigid body translation?: a). Yes, b). No, Answer: No, By strict definition, this object exhibits pure rotation about A . All points move in circular paths.

Problem 5:

Two uniform cylinders of mass m_1 and m_2 and radius R_1 and R_2 are welded together. This composite object rotates without friction about a fixed point. An inextensible massless string is wrapped without slipping around the larger cylinder. The two ends of the string are connected to the ground via, respectively, a spring of constant k and a dashpot of constant b . The smaller cylinder is connected to a block of mass m_0 via an inextensible massless strap wrapped without slipping around the smaller cylinder. The block is constrained to move only vertically.

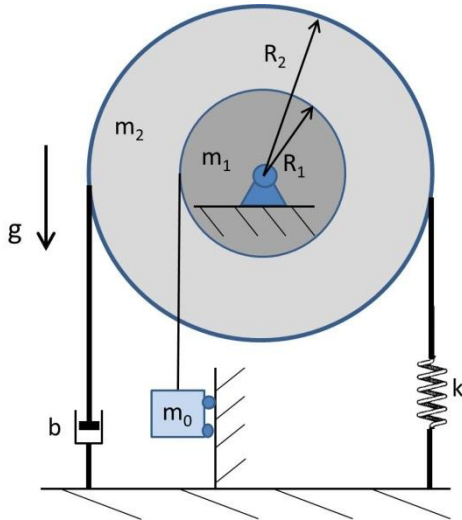

a) Find expressions for T and V the kinetic and potential energy of the system.

Concept question: For small values of the dashpot constant, b , if this single degree of freedom system is given an initial displacement from its static equilibrium position, will it exhibit oscillatory motion after release?

a)Yes, b)No. Answer: Yes, it will oscillate about its static equilibrium position.

Problem 6:

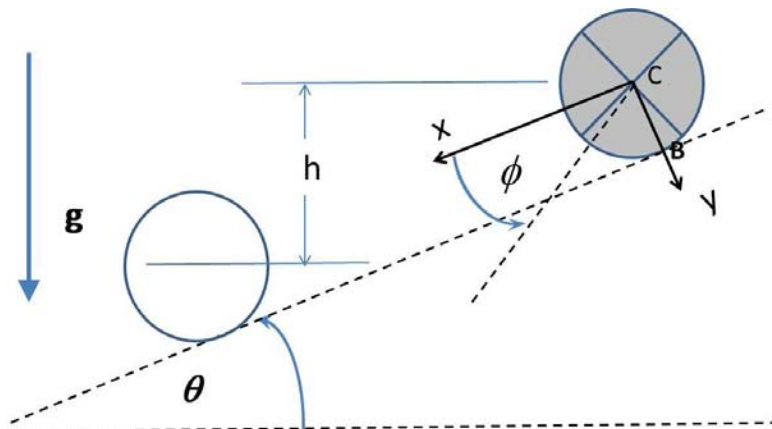

A wheel is released at the top of a hill. It has a mass of 150 kg, a radius of 1.25 m, and a radius of gyration of $k_G = 0.6$ m.

a). After release from the top of the hill the wheel rolls without slip down the hill. Find the kinetic energy, T , after the center of mass of the wheel has descended a vertical height „ h “.

b). Compute the ratio of the translational kinetic energy to the total kinetic energy of the system.

Concept question a) If the wheel slips during its passage down the hill, is it correct to model it as a planar motion problem. A). Yes, b). No, Answer: Yes, its translational motion is confined to the x-y plane and the axis of rotation is a principal axis which is perpendicular to the x-y plane.

Problem 7: The cart shown in the figure has mass m_0 . It has an inclined surface as shown. A uniform disk of mass m , and radius R , rolls without slip on the inclined surface. The disk is restrained by a spring, K_1 , attached at one end to the cart. The other end of the spring attaches to an axel passing through the center of the disk. The cart is restrained by a second spring, K_2 , which is attached to a non-moving wall.

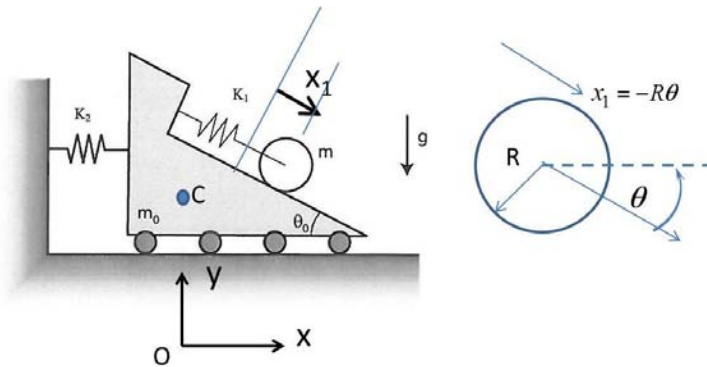

- Find expressions for the kinetic energy, T , and potential energy, V , for the system.
- Use Lagrange equations to find the equations of motion of the system.

Concept question: How many independent coordinates are required to account for the kinetic and potential energy in the system: a). 1, b). 2, c). 3. Answer: b). This system has two degrees of freedom and requires two independent coordinates.

MIT OpenCourseWare
<http://ocw.mit.edu>

2.003SC / 1.053J Engineering Dynamics
Fall 2011

For information about citing these materials or our Terms of Use, visit: <http://ocw.mit.edu/terms>.